



Triploid Grass Carp Information Sheet

Texas Parks and Wildlife Department - Inland Fisheries Division

Introduction

The grass carp, also known as white amur, is a vegetarian fish native to the Amur River in Asia. The U. S. Fish and Wildlife Service introduced grass carp into the United States in 1963 for experimental purposes. Because this fish feeds on aquatic plants, it can be an effective biological tool for control of nuisance vegetation. Since 1992, Texas has allowed stocking of triploid grass carp, a sterile form of the species, with a permit from the Texas Parks and Wildlife Department (TPWD).

Facts

Triploid grass carp:

- offer a biological alternative for aquatic plant control.
- are sterile and will not reproduce.
- are only distantly related to the undesirable European carp, and share few of its habits.
- live for at least 10 years and probably longer in Texas waters.
- grow rapidly and may exceed 60 pounds.
- feed only on plants, not on fish eggs or young fishes.
- feed from the top of the plant downward; however, where all submersed vegetation has been eliminated, the water can become turbid, as hungry fish eat the organic material out of the sediments.
- have definite food preferences. Plants like water lilies, filamentous algae (pond scum or moss), muskgrass and Eurasian milfoil are not preferred. Bushy and American pondweeds and hydrilla are preferred foods.
- **are not effective for control of bulrush, filamentous algae (pond scum or moss), water primrose, coontail, Eurasian milfoil, or cattails.**
- go dormant during the winter and resume intensive feeding when water temperatures reach 68° F.
- are difficult to catch with conventional fishing methods.

Stocking Considerations

- Triploid grass carp are inexpensive compared to most other aquatic vegetation control methods.
- Depending on plant types, plant density, and stocking rate, it may take several years to achieve control using triploid grass carp. Restocking, generally every 5 to 7 years, is needed for maximum effectiveness.
- The types of plants triploid grass carp prefer may also be important for fish habitat and waterfowl food. Aquatic vegetation can be important in maintaining good fish communities and providing food for other wildlife species.
- If the water body is overstocked, all submersed aquatic plants may be eliminated. Removing excess fish can be difficult.
- If insufficient numbers of triploid grass carp are stocked, less-favored plants may become overabundant.
- Stocking triploid grass carp may result in alga blooms and reduced water clarity.

Emigration Barrier

Triploid grass carp readily seek flowing water and often escape before controlling nuisance aquatic plants. Escapement of the stocked fish can reduce or eliminate their potential for plant control within targeted areas, and can threaten beneficial plants outside of targeted areas. **Impoundments on permanently flowing creeks, or those that overflow frequently, should not be stocked with triploid grass carp unless they can be effectively screened.** Therefore, emigration barriers are required for many, and recommended for most, water bodies being stocked with triploid grass carp. In cases where emigration cannot be prevented, chemical or mechanical control of aquatic plants is recommended.

With few exceptions, the best screening device for nearly all outlet types is the horizontal parallel steel-bar design. The orientation of the bars allows unrestricted passage of small debris, thereby minimizing maintenance, clogging, and flooding concerns. Bar thickness of ¼- to ½- inch is preferred. Round bar stock will facilitate debris passage. For a spillway barrier (Figure 1), the horizontal bars are attached to vertical support posts (minimum ¼-inch diameter) spaced 4 feet apart. Horizontal bars should be spaced 2 inches apart. The barrier should span the entire spillway. Since triploid grass carp are excellent jumpers, barrier height should extend 2 feet above the normal high water level.

For capping a drainage pipe (Figure 2), a similar bar design should be used. Extending the bars 4-5 feet above the overflow pipe allows water to rise over debris and begin flowing again should the screen become clogged.

Welded wire and chicken wire are not effective as barrier materials. These types of materials readily clog with debris and the force of even a small amount of water can destroy the barrier. Clogged barriers may threaten the integrity of dams.

Figure 1 - Spillway Barrier.

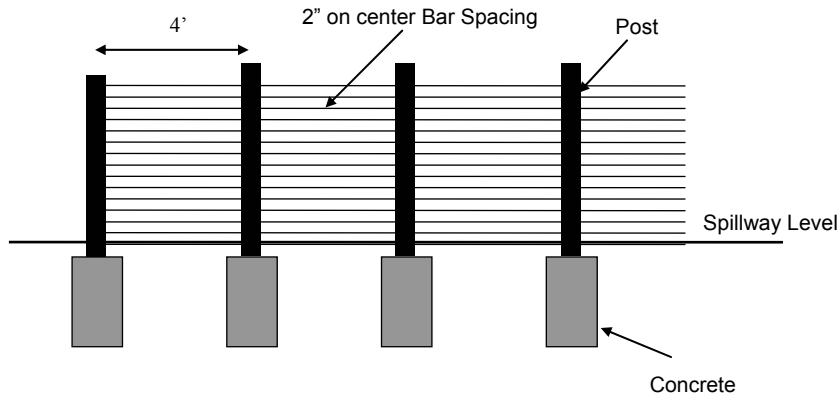
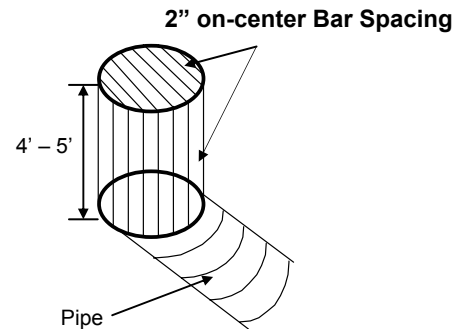

Figure 2 - Drainage Pipe Cap.



Permits

Before stocking, water body owners, their agents, or controlling authorities must obtain a Triploid Grass Carp Permit from the Inland Fisheries Division of the TPWD. Permit applications and additional information on triploid grass carp can be obtained by emailing ifpermits@tpwd.texas.gov. Once the application has been received, it will be reviewed by a District Fisheries Management Biologist. In some cases, a TPWD staff member will contact you or make an on-site visit to ensure the fish will not escape into public waters. Allow 4-5 weeks for the entire permit process.

Stocking of triploid grass carp is not allowed in some environmentally sensitive areas where threatened, endangered, or unique species occur.

After you receive an approved permit, triploid grass carp **must** be purchased from a commercial fish farmer who holds an Exotic Species Permit authorizing possession of triploid grass carp. A list of permitted fish farmers will be provided with your approved permit.

Many have asked, "Since triploid grass carp are sterile, why is a permit required? Why be concerned with escapement into public water?" These fish are permitted so that TPWD can keep track of the location and number of grass carp in the environment, especially near sensitive areas. We are concerned about escapement because, although triploid grass carp can't reproduce, they can live for years, potentially migrate to sensitive areas, and consume a great deal of vegetation. Texas' outstanding freshwater fisheries are heavily dependent on natural aquatic vegetation. Aquatic plants provide the following benefits:

- cover for young fish to hide from predators
- food and cover for many insects that fish eat
- protection from currents and silt for fish eggs in nests
- structure that sportfish use for shade and camouflage, which in turn helps anglers locate them.

Ensuring that triploid grass carp remain where they are stocked makes economic sense for the water body owner and helps protect beneficial aquatic vegetation in our public waters.

Stocking Facts

- Triploid grass carp should be 10-12 inches long when stocked. Smaller carp are likely to be eaten by other fish.
- To enhance effectiveness of triploid grass carp, overabundant vegetation should first be reduced by winter die-off, herbicide treatment, or water-level drawdown to promote grazing on re-growth. Early spring is a good time to stock.
- The recommended stocking rate for triploid grass carp is **five per acre if the water body has 50% or less plant coverage, and 10 per acre if plant coverage is greater than 50%**. If warranted, the stocking rate can be increased with consent of your local TPWD fisheries management biologist.
- If you need additional fish, it will be necessary to apply for a **new** permit. A request can be made by emailing ifpermits@tpwd.texas.gov.

Additional Grass Carp and Aquatic Plant Information Via the Internet:

For more information about the Texas Parks and Wildlife Department Triploid Grass Carp Program, grass carp biology, or aquatic plants, visit the Texas Parks and Wildlife Department web page at http://www.tpwd.state.tx.us/landwater/water/environconcerns/nuisance_plants. Links to other resources are also provided.